



Bowler
pan and tilt



- | | |
|---------------------------------------|--|
| Strong lightweight construction | Dual process heat treated gravity die cast aluminium casing |
| Highly reliable with minimal backlash | Precision turned and milled internal components with ball races on major axes |
| Built to last | Stainless steel fastenings |
| Weatherproof | 'O' rings and lip seals. IP rating 68 (assuming the supplied mating connector is used and fitted to the manufacturers specification) |
| Long operational life | Maintenance free, two year warranty |
| Easy to install | Simple external limit switch adjustment to 350 degrees travel |
| Mounting plate | Suitable for all small housings |
| Corrosion resistant finish | Colour options available |
| Regenerative braking | Aids rapid deceleration |





Bowler pan and tilt

The Bowler range of miniature pan and tilt heads consist of 24VDC and 12VDC units in both over the top and side mount configurations.

The units are extremely compact, (only one third the volume of the Topper.) They are externally robust and aesthetically designed to an IP 68 rating providing a rugged and stable mobile camera platform for use in most CCTV installations where a smaller size is required. A fresh design approach has introduced a simple but effective limit switch facility and larger bearings with a broader spread to allow a much higher load capacity on side arm configurations. The gearbox has been designed to provide higher gear ratios which give lower speeds without costly modifications.

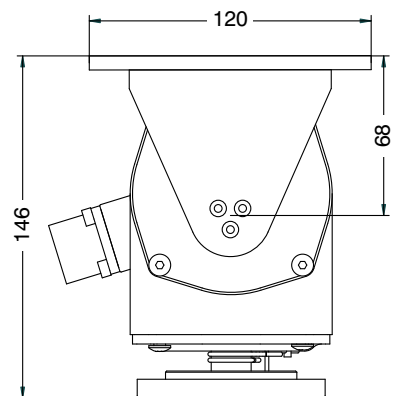
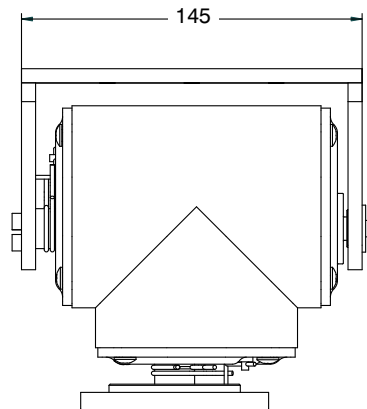
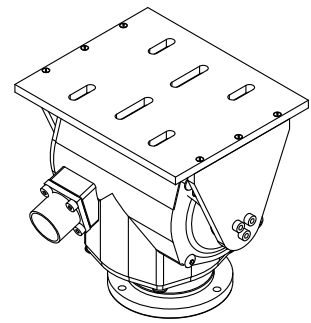
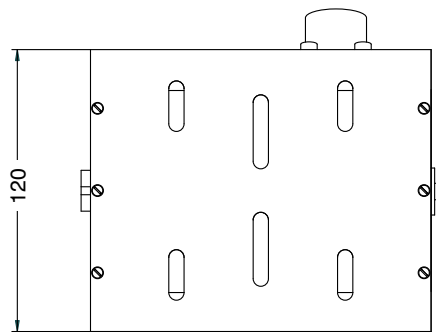

Dimensions (mm nominal)		Side mount	Over the top
Height		133	146
Width to platform face		145	145
Width to platform outer edge		307	N/A
Weight (kg)		<2.3	<2.3
Fixing centres	Base	3 holes tapped M5 on 70 PCD	
	Platform	8 holes 6.35 dia. on 101.6 dia. PCD	6 slots (see diagram)
Voltages	24VDC or 12VDC nominal		
Speeds (°/sec)			
Pan	30, 10		30, 10
Tilt	10		10
Capacity	10 kg in side mounting configuration, any speed 6 kg in over the top configuration @ 30/10 deg/sec (max load can only be achieved by using a slow speed gearbox and a balanced load)		
Operational Angles (°)	Pan		Tilt
Side mount	350		± 180
Over the top	350		-90 to +30
Backlash	Less than 0.15		
Control cable	Mating connectors supplied		
House colour	Goose Grey, textured, semi gloss (BS4800 00 A05)		
Maintenance	None required		
Temp. range (°C)	-20 to + 50		



Metham Aviation Design Limited
Station Approach, Four Marks, Alton
Hampshire GU34 5HN, UK

Tel: +44 (0)1420 565618. Fax: +44 (0)1420 565628
Email: info@madcctv.com Web: www.madcctv.com





615 PCR
Topper



620 PCR
Bowler
(available with standard
or shortened column)



Topper and Bowler
continuous rotation
pan & tilts

- | | |
|---------------------------------------|--|
| Strong lightweight construction | Dual process heat treated gravity die cast aluminium casing |
| Highly reliable with minimal backlash | Precision turned and milled internal components with ball races on major axes |
| Built to last | Stainless steel fastenings |
| Weatherproof | 'O' rings and lip seals. IP rating 68 (assuming the supplied mating connector is used and fitted to the manufacturers specification) |
| Long operational life | Maintenance free, two year warranty |
| Versatile | 24 way slip ring assembly for all cabling requirements and power |
| Easy to install | No external pan limit switch to set |
| Mounting plate | Suitable for all housings |
| Corrosion resistant finish | Colour options available |
| Regenerative braking | Aids rapid deceleration |





Topper and Bowler continuous rotation pan & tilts

The Continuous Rotation option has been designed to complement the highly successful Homburg, Topper and Bowler pan and tilt heads.

The head incorporates an extruded aluminium column, which houses the slip ring assembly and connectors and also acts as a column spacer.

The slip ring assembly provides a 24 way slip ring with 4 contacts per ring providing all necessary cable management and power.

There is also some spare capacity for user defined requirements.

The shaft is fixed to the column by utilising a locking taper and the column itself is fully adjustable in rotation to allow orientation of the connectors. As in all MAD heads, the limit stops are externally accessible for ease of set up.

The gearbox has been designed to provide higher gear ratios which give lower speeds without costly modifications.

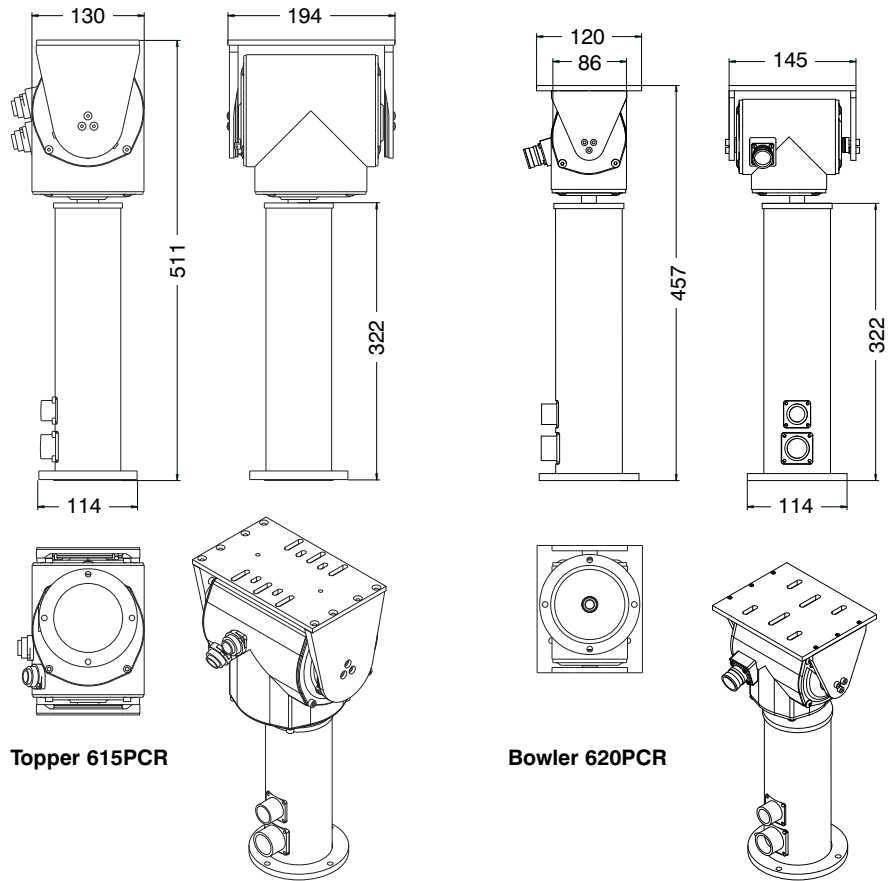

Topper 615PCR

Bowler 620PCR

	615PCR		620PCR	
Dimensions (mm nominal)	Side mount	Over the top	Side Mount	Over the top
Height	493	511	441	457
Width to platform face	183	183	145	145
Width to platform outer edge	347	N/A	307	N/A
Slip ring	24 way with 4 contacts per ring. (240v AC 2Amps)			
Weight (kg)	< 8kg	< 8kg	< 4.3kg	< 4.3kg
Fixing centres	Base	4 holes 6.35 dia on 4" (101.6) PCD		
	Platform	4 holes 6.5mm dia on 101.6mm (4") PCD/square 4 holes 6.35mm dia on 101.6mm (4") PCD/diamond 4 slots 6.35mm wide x 30mm long in pairs In line with camera axis		
Voltages	24VDC, 12VDC nominal, 240VAC, 24VAC		24VDC, 12VDC	
Speeds (°/sec)	AC		DC	
Pan	3,6,12		12,18,24,32,48 30,10	
Tilt	3,6		12,18 10	
Capacity	25 kg in side mounting (Maximum load can only be achieved by using a slow speed gearbox and a balanced load)		6 kg in over the top 10 kg in side mounting	
Operational Angles (°)	Pan	Tilt		
Side Mount	Cont 360	+/- 180		
Over the Top	Cont 360	-90 to +25		
Backlash	Less than 0.15			
Control cable	Mating connectors supplied			
House colour	Goose Grey, textured, semi gloss (BS4800 00 A05)			
Maintenance	None required			
Temp. range (°C)	-20 to + 50			



Metham Aviation Design Limited
Station Approach, Four Marks, Alton
Hampshire GU34 5HN, UK

Tel: +44 (0)1420 565618. Fax: +44 (0)1420 565628
Email: info@madcctv.com Web: www.madcctv.com

